

Labnet Excel™ Single- and Multi-channel Electronic Pipettors

Instruction Manual

Catalog Numbers:

P3600L-10	P3608L-10	P3612L-10
P3600L-20	P3608L-20	P3612L-20
P3600L-200	P3608L-200	P3612L-200
P3600L-1200	P3608L-1200	P3612L-1200



Table of Contents

- 1.0 Introduction1
- 2.0 Safety Information1
 - 2.1 Operation Safety Precautions.....1
 - 2.2 Battery Safety1
- 3.0 Specifications2
- 4.0 Getting Started3
 - 4.1 Unpacking.....3
 - 4.2 Inserting the Battery.....3
 - 4.3 Charging the Battery3
 - 4.4 Start Pipetting.....4
 - 4.5 Blow-out Operation.....4
 - 4.6 Hanger Installation4
- 5.0 Overview5
 - 5.1 Audible Signals6
 - 5.2 Function Map.....6
- 6.0 SYS (System) Mode6
 - 6.1 Aspirating Speed.....6
 - 6.2 Dispensing Speed.....7
 - 6.3 Audible Signals7
 - 6.4 Blow-out7
 - 6.5 Reverse Pipetting7
 - 6.6 Program Storing and Recall.....7
- 7.0 AUTO (Automatic Pipetting) Mode8
 - 7.1 Setting Up the Volume in AUTO Mode Only8
 - 7.2 Setting Up the Volume in AUTO + MIX Mode8
- 8.0 MD (Multiple Dispensing) Mode8
- 9.0 MIX Mode.....9
- 10.0 SE (Sequential Aspirating/Dispensing) Mode.....9
 - 10.1 SA (Sequential Aspirating) Mode9
 - 10.2. SD (Sequential Dispensing) Mode..... 10
- 11.0 Sterilization 10
 - 11.1 Removal of the Lower Piston Assembly 11
 - 11.2 Reattach the Lower Piston Assembly..... 11
- 12.0 Tip Ejector Height Adjustment 12
- 13.0 Maintenance..... 12
- 14.0 Troubleshooting..... 12
- 15.0 Limited Warranty..... 13
- 16.0 Equipment Disposal 13

1.0 Introduction

Labnet Excel™ electronic pipettors feature an accurate and efficient, as well as ergonomic and lightweight design. Researchers can program these state-of-the-art products to conduct different pipetting tasks. More accurate and comfortable pipetting can be easily achieved without any concern of finger stress or injury.

- ▶ High accuracy and precision
- ▶ Low forces
- ▶ Useful, practical operation protocols, such as Automatic Pipetting (AUTO) with Mixing (MIX) option, Multiple Dispensing (MD), Mixing (MIX), and Sequential Aspirating/Dispensing (SE)
- ▶ 9 user-defined program sets
- ▶ 5 speeds for aspirating and dispensing
- ▶ Lithium-ion battery provides extended use on a single battery charge
- ▶ Ergonomic design
- ▶ Automatic calibration
- ▶ User-friendly graphic operation interface
- ▶ Adjustable tip ejector
- ▶ Automatically remembers the last-used pipetting protocol and settings
- ▶ Complies with CE, ISO-8655, Good Laboratory Practice (GLP)

2.0 Safety Information

Use of this product in any manner not specified by the manufacturer may impair the safety protection provided by the equipment and may result in physical damage and/or personal injury. Please read all operating instructions in this manual prior to use of this equipment.



This symbol indicates a potential risk and alerts you to proceed with caution.



2.1 Operation Safety Precautions

When using infectious, radioactive, toxic, and other solutions which may pose health risks, please observe appropriate safety precautions.

- ▶ Do not use the Labnet Excel electronic pipettor in a potentially explosive environment or with potentially explosive chemicals.
- ▶ When using organic solvents or corrosive chemicals, please check their compatibility with the pipet tips and the Labnet electronic pipettor.
- ▶ Repairs should be carried out by authorized service personnel only. Contact Corning Customer Service for information on authorized service options.
- ▶ Use original parts and accessories only.



2.2 Battery Safety

The Labnet Excel electronic pipettors operate on a small but powerful Lithium-ion battery. Misuse or abuse of the Lithium-ion battery may cause damage or injury through fire, electric shock, or chemical leakage. Please read and understand all warnings before using the battery.

- ▶ When storing the battery, do not allow it to come into contact with any metallic surfaces.
- ▶ Do not incinerate the Lithium battery or expose it to excessive heat.
- ▶ Do not short-circuit, puncture, crush, disassemble, damage, force over-discharge (reversal) or modify the battery.
- ▶ Do not expose the battery to water or moisture.
- ▶ Do not drop or subject the battery to strong impacts.
- ▶ Only use the battery specified in this manual and specified battery charging unit or DC-in jack to charge the battery.
- ▶ Do not use a leaking battery.
- ▶ If charging is not completed within the specified time period, unplug the charger and discontinue charging immediately.
- ▶ The charger and battery temperature rises with extended periods of use. Care should be taken to avoid burns.
- ▶ Burns may result if the battery is removed immediately after extended period of use.
- ▶ If fluid from the battery enters your eye, immediately rinse the eye with plenty of fresh water and contact a doctor. If fluid from the battery makes contact with your skin or clothing, wash the area thoroughly with water.

3.0 Specifications

Single-channel

Cat. No.	Model	Volume Range (µL)	Increment (µL)	Accuracy (%)	Precision (%)
P3600L-10	LE10-1	0.5 - 10	0.1	±4.0 to ±1.0	≤2.5 to ≤0.4
P3600L-20	LE20-1	2 - 20	0.1	±4.0 to ±1.0	≤2.5 to ≤0.4
P3600L-200	LE200-1	10 - 200	1	±2.5 to ±0.6	≤1.0 to ≤0.15
P3600L-1200	LE1200-1	100 - 1200	1	±2.5 to ±0.5	≤0.6 to ≤0.15

8-channel

P3608L-10	LE10-8	0.5 - 10	0.1	±4.0 to ±1.5	≤2.5 to ≤0.5
P3608L-20	LE20-8	2 - 20	0.1	±4.0 to ±1.0	≤2.5 to ≤0.5
P3608L-200	LE200-8	10 - 200	1	±3.0 to ±0.6	≤1.0 to ≤0.15
P3608L-1200	LE1200-8	100 - 1200	1	±3.0 to ±0.5	≤0.8 to ≤0.2

12-channel

P3612L-10	LE10-12	0.5 - 10	0.1	±4.0 to ±1.5	≤2.5 to ≤0.5
P3612L-20	LE20-12	2 - 20	0.1	±4.0 to ±1.0	≤2.5 to ≤0.5
P3612L-200	LE200-12	10 - 200	1	±3.0 to ±0.6	≤1.0 to ≤0.15
P3612L-1200	LE1200-12	100 - 1200	1	±3.0 to ±0.5	≤0.8 to ≤0.2

NOTE: Labnet Excel™ electronic pipettor accuracy and precision specifications have been attained using Labnet pipet tips. Labnet guarantees accuracy and precision only if Labnet tips or other approved tips are used.

Operation mode	<ul style="list-style-type: none"> ▶ Automatic Pipetting (AUTO) with Mixing (MIX) option ▶ Multiple Dispensing (MD) ▶ Mixing (MIX) ▶ Sequential Aspirating/Dispensing (SE) ▶ System Setup (SYS)
Program memory	9 programs
Aspirating/dispensing speed	5 speeds
Auto-calibration	Yes
Piston motor	High precision stepping motor
Power saving feature	Yes, after 10 minutes
Power adapter	100/120/220/240V, AC/DC 5V
Audible alerts	Yes
Autoclavable	Yes, lower manifold only
Operating temperature	5°C to 50°C
Operating humidity	0 to 85% RH
Battery	920 mAh/3.6V or above, Lithium-ion

4.0 Getting Started

4.1 Unpacking

The package includes:

- ▶ Labnet Excel™ electronic pipettor
- ▶ Battery
- ▶ Battery installation guide
- ▶ AC/DC power adapter
- ▶ Hanger with sticker
- ▶ Pipet tips (sample non-filtered pipet tips: 1 x 10 μ L, 1 x 200 μ L, 1 x 1000 μ L)
- ▶ Quick start guide
- ▶ Instruction manual
- ▶ Calibration report

If any items are missing, damaged, or incorrect, please contact your distributor or sales representative.

NOTE: Charge the battery before first-time operation.

4.2 Inserting the Battery

Remove the battery cover by pressing the battery cover latch and moving the cover outward (Figure 1). Plug in the battery connector and insert the battery (Figure 2). Close the cover of the battery compartment. Press the Reset button to power on and calibrate the Labnet Excel electronic pipettor.

NOTE: After a charged battery is inserted, the Labnet Excel electronic pipettor will automatically perform a calibration routine.

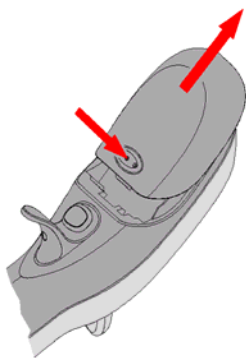

Figure 1. Open the battery cover.

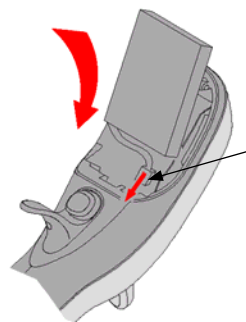

Figure 2. Insert the battery connector into the bottom right recess first, then place the battery into position.



4.3 Charging the Battery

Attach the included AC/DC power adapter to the pipettor to charge the battery.

Insert the battery into the battery compartment. Insert the DC-in plug of the power adapter into the DC-in jack (Figure 3). Connect the power plug into the external power source.

NOTES:

- ▶ Connecting the power plug before inserting the battery will inactivate the charging process.
- ▶ Labnet Excel™ electronic pipettors can be used during charging.
- ▶ Do not over-charge the battery for a long period of time.
- ▶ Do not insert or remove the battery during the charging process, as this may cause battery or PCBA damage.

The indicator bar inside the battery symbol () will blink during the charging process. When the battery is fully charged (), the blinking will stop and the Labnet Excel electronic pipettor will beep once.

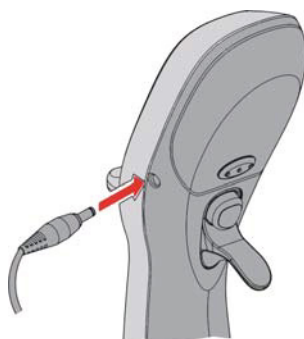

Figure 3. Connect the AC/DC adapter to charge the battery.

4.4 Start Pipetting

There is no power On/Off button on the Labnet Excel electronic pipettor. When a fully charged battery is inserted, the pipettor will be switched on. It will perform a calibration routine and the LCD display will appear (Figure 7). Press any keypad button or the Plunger button to enter the function mode selection. The Labnet Excel electronic pipettor will enter sleep mode and automatically power off if not used for more than 10 minutes.

NOTE: In sleep mode, if the power adapter is connected to the pipettor, the LCD display will show the battery charging symbol. If the DC power adaptor is not connected, the LCD display will show nothing.

Select the desired function mode and settings (see Sections 6 through 10) before pipetting. After the initial setup, attach the correct-sized tips to the cone(s) of the pipettor before operation.

Model			Volume Range (µL)	Tip (µL)
Single-channel	8-channel	12-channel		
LE10-1	LE10-8	LE10-12	0.5 - 10	10
LE20-1	LE20-8	LE20-12	2 - 20	10*
LE200-1	LE200-8	LE200-12	10 - 200	200
LE1200-1	LE1200-8	LE1200-12	100 - 1200	1000**/1200

*Most manufacturers' 10 µL tips will accurately accommodate 20 µL.

**Most 1000 µL tips have enough space to hold up to 1200 µL of sample.

The cones of the Labnet Excel electronic pipettor are designed to fit a wide variety of manufacturers' pipet tips. However, the published accuracy and precision specifications for the Labnet Excel electronic pipettors are guaranteed only when using Labnet BioFree™ tips. Contact Corning Customer Service for pipet tip ordering information.

The Labnet Excel electronic pipettor is an ergonomic instrument designed to reduce hand fatigue and repetitive strain injury. In order to maximize the benefits of the Labnet Excel electronic pipettor's design, the instrument should be held as shown in Figure 4. Use your index finger to press the Plunger button, and use your thumb to press the Tip ejector.

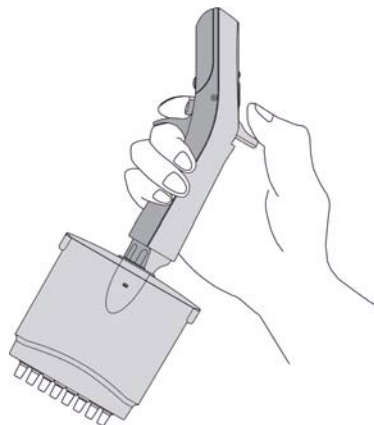

Figure 4. Correct hand position.

4.5 Blow-out Operation

The automatic Blow-out function simulates the blow-out function in manual pipettors. With the Blow-out function selected, the user can press the Plunger button once to dispense the liquid, and the piston will travel an extra distance to blow out any remaining liquid. The piston will then pause and return to its starting position. Alternatively, the user can press and hold the Plunger button to dispense. The piston will travel the extra distance to blow out the remaining liquid and remain in that position until the plunger is released. When the Plunger button is released, the piston will return back to its starting position.

4.6 Hanger Installation

The Labnet Excel™ electronic pipettor hanger can be attached to a shelf or counter using the sticker (Figure 5). The finger rest of the Labnet Excel electronic pipettor locks into the hanger and keeps the pipettor in a vertical position.

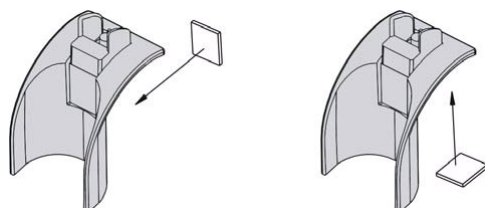

Figure 5. Labnet Excel electronic pipettor hanger installation.

5.0 Overview

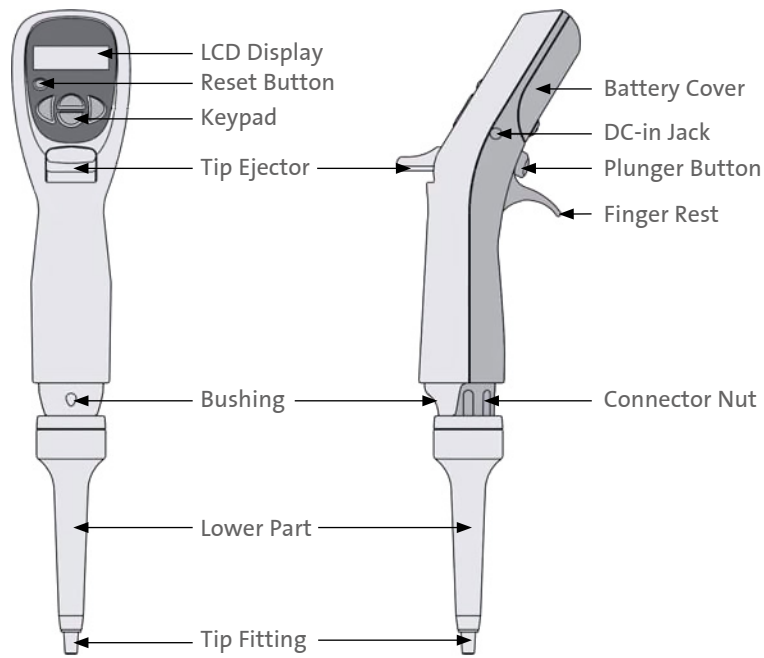

Figure 6. Single-channel Labnet Excel electronic pipettor overview.

TIP: The plunger button (Figure 6) can be used to increase the volume and to change modes and settings the same as the Up button (Figure 7) during function mode selection and volume settings. This feature can speed up the setting process.

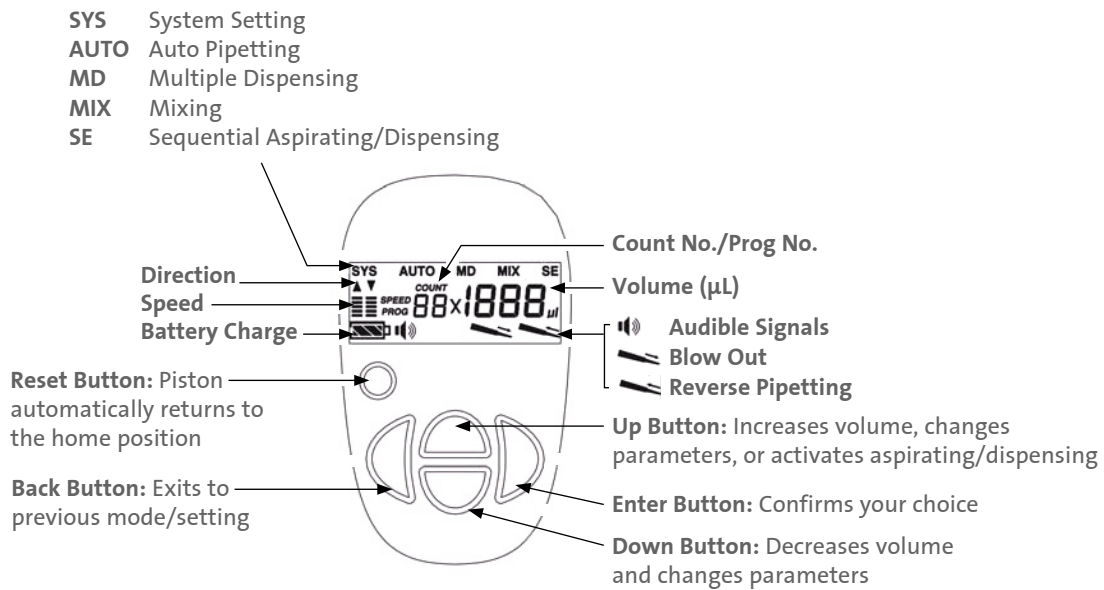

Figure 7. LCD display panel.

5.1 Audible Signals

The audible signals are beneficial when familiarizing yourself with the operating procedure of the Labnet Excel™ electronic pipettor. They can also be switched off if desired (Section 6.3.)

- ▶ **Low-tone beep:** Aspirating
- ▶ **High-tone beep:** Dispensing/error codes
- ▶ **2 beeps:** MD/MIX/SE mode cycle or Reset routine is completed

5.2 Function Map

The main menu of the Labnet Excel™ electronic pipettor includes five function modes (SYS, AUTO, MD, MIX, and SE). Each mode includes various function settings (Figure 8).

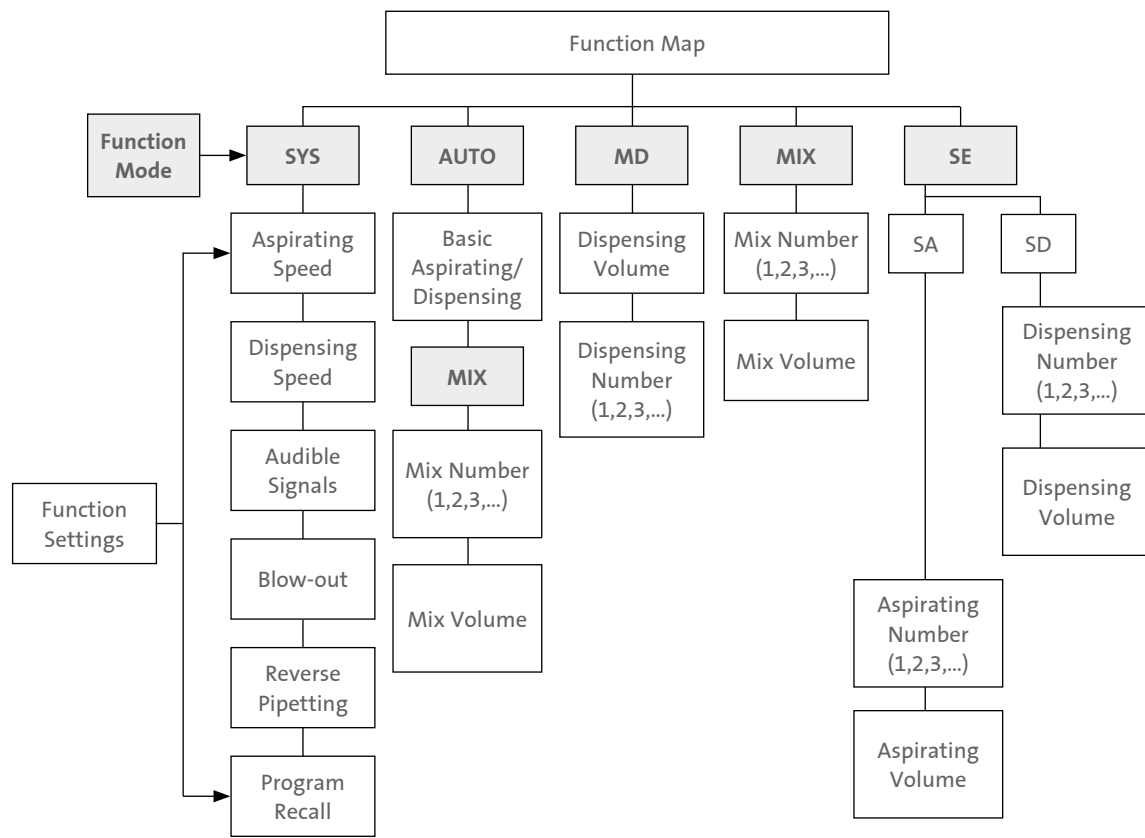



Figure 8. Function map.

6.0 SYS (System) Mode







SYS mode is used to set up the function settings before pipetting. Once the user has selected and stored these settings, they will no longer need to set up these settings before every use. There are 6 function settings (Aspirating Speed, Dispensing Speed, Audible Signals, Blow-out, Reverse Pipetting, and Program Recall) in SYS mode.

NOTES:





- ▶ These 6 function settings are sequential procedures. To store these settings in memory, users have to complete the whole setting procedure and press the Enter button  when the LCD displays PROG.
- ▶ Users can use the Up/Down button  to move back and forth to the previous function settings.

6.1 Aspirating Speed

There are 5 speeds available for both aspirating and dispensing.





1. Press the Back button  to enter the function mode selection. Then press Up/Down button  to select the SYS symbol (flashing).
2. Press the Enter button  to confirm the selection of SYS mode and the aspirating speed symbol  will flash.
3. Press the Up/Down button  to change the aspirating speed (←: Slowest, ≡: Fastest).
4. Press the Enter button  to confirm the speed selection and move to the Dispensing Speed function setting.

6.2 Dispensing Speed

1. The Dispensing Speed symbol  should now be flashing.
2. Press the Up/Down button  to change the dispensing speed (—: Slowest, : Fastest).
3. Press the Enter button  to confirm the speed selection and move to the Audible Signals function setting.

6.3 Audible Signals

Refer to Section 5.1 for the definition of audible signals.









1. The Audible Signals symbol should now be flashing.
2. Press the Up/Down button  to select the preference (: On, : Off).
3. Press the Enter button  to confirm the selection and move to the Blow-out function setting.

6.4 Blow-out

The automatic blow-out function simulates the blow-out function in manual pipettors.

NOTE: To avoid leftover droplets remaining in the tip, the blow-out setting is recommended for all protocols.





The blow-out setting will not be performed in the Reverse Pipetting setting.

1. The Blow-out symbol  should now be flashing.
2. Press the Up/Down button  to select the preference (: On, : Off).
3. If  is selected, pressing the Enter button  will confirm the selection and move to the PROG setting. If  is selected, pressing the Enter button  will confirm the selection and move to the Reverse Pipetting setting.

NOTE: It is important to withdraw the tip quickly from the dispensed sample vessel after dispensing if blow-out is selected, as the piston will automatically retract a short distance. When holding the Plunger button during dispensing, the piston will travel the distance to blow out, and remain there until the Plunger button is released.

6.5 Reverse Pipetting

The automatic reverse pipetting is to reserve the final drop of sample. The Labnet Excel™ electronic pipettor will not perform reverse pipetting in MIX or SA modes.



1. The Reverse Pipetting symbol  should now be flashing.
2. Press the Up/Down button  to choose the preference (: On, : Off).
3. Press the Enter button  to confirm the selection and move to the PROG setting.

NOTE: If Reverse Pipetting is selected, the user has to press the Plunger button one more time after pipetting to dispense the remaining liquid during the pipetting. “rE” will appear on the LCD to remind the user to dispense the remaining liquid.





6.6 Program Storing and Recall

The memory program includes 9 storage locations (PROG 01 to 09). Your favorite operating modes with user-selected settings can be stored to these locations for future recalls. Before setting the programs, you must have programmed operating mode (e.g., AUTO, MD modes, etc.).

Store Operating Mode to Storage Locations

1. Complete the set up of function mode (e.g., AUTO, MD, MIX mode).
2. Press and hold the Down button  for 3 seconds to enter PROG mode.
3. Press the Up/Down button  to select PROG number from 01 to 09.
4. Press the Enter button  to confirm the location selection and save the settings.

Recall Stored Programs from the Storage Location

1. Press the Back button  to enter the function mode selection. Then, press the Up/Down button  until the SYS symbol flashes.
2. Press the Enter button  repeatedly until the PROG symbol flashes.
3. Press the Up/Down button  to select the PROG number.
4. Press the Enter button  to confirm the selection.
5. Press the Plunger button to operate the Labnet Excel electronic pipettor in the selected program.





NOTE: During the recall process, the changes of other settings will not be stored.

7.0 AUTO (Automatic Pipetting) Mode





AUTO mode includes:

- ▶ **AUTO mode only:** The Labnet Excel™ electronic pipettor performs the aspirating and dispensing of a set liquid volume.
- ▶ **AUTO + MIX mode:** The Labnet Excel electronic pipettor performs mixing after automatic pipetting is completed. This mode is ideal for serial dilution applications.









7.1 Setting Up the Volume in AUTO Mode Only

1. Press the Back button  to enter the mode selection. The AUTO symbol will flash. If not, press Up/Down button  to select AUTO mode.
2. Press the Enter button  to confirm the mode selection.
3. Use the Up/Down button  to select the desired pipetting volume.
4. Press the Enter button  to confirm volume. The Labnet Excel electronic pipettor is ready for pipetting.

TIPS:

- ▶ The user can use the Plunger button instead of the Up button  to speed up the volume setting.
- ▶ To change the volume changes during pipetting, press the Enter button  to select pipetting volume and use the Up/Down button  to select the desired volume. Press the Enter button  again to confirm the desired pipetting volume.

7.2 Setting Up the Volume in AUTO + MIX Mode

1. Press the Back button  to enter the mode selection. The symbol AUTO will flash. If not, press the Up/Down button  to select AUTO mode.
2. Press and hold the Enter button  for 3 seconds to enter AUTO + MIX mode selection. Both AUTO and MIX symbols will appear. The pipetting volume will appear and flash.
3. Use the Up/Down button  to select the desired pipetting volume.
4. Press the Enter button  to confirm selected volume and enter MIX mode setting. The COUNT symbol will flash.
5. Press the Up/Down button  to select the desired mixing cycle counts.
6. Press the Enter button  to confirm selected mixing cycle counts. The mixing volume will flash.
7. Press the Up/Down button  to select the desired mixing volume.
8. Press the Enter button  to confirm selected mixing volume.







Press the Plunger button to aspirate the sample. Press the Plunger button again to dispense the sample and the LCD will display the mixing cycle count and volume. Press the Plunger to mix and dispense the sample. At the end of mixing, the sample will remain in the tip and LCD will display bL. Press the Plunger to dispense the remaining sample using the blow-out function.

8.0 MD (Multiple Dispensing) Mode

In MD mode, the Labnet Excel electronic pipettor performs repetitive dispensing of a selected volume.







NOTE: When using Multiple Dispense (MD) mode, it is recommended to select Reverse Pipetting in the System (SYS) settings for best results. Reverse Pipetting is used in MD mode to provide better accuracy and precision with repeated dispensing.

Reverse Pipetting means that an extra volume of liquid will be left in the tip at the end of a multiple dispensing cycle, and the display will show to remind the user to dispense this residual volume before repeating the multiple dispense cycle.

1. Press the Back button  to enter the mode selection.
2. Press the Up/Down button  to make the MD symbol flash.
3. Press the Enter button  to confirm the selection. The default pipetting volume symbol will then appear.
4. Use the Up/Down button  to select the desired pipetting volume.
5. Press the Enter button  to confirm volume selection. The COUNT symbol will flash.
6. Use the Up/Down button  to select the desired pipetting count.
7. Press the Enter button  to confirm the pipetting count. The pipetting volume will show the total aspirating volume.

After the settings have been entered, press the Plunger button to aspirate the sample according to the pipetting volume. Then press the Plunger button repeatedly to dispense the samples according to the pipetting count. When the last count is reached, two beeps will indicate that the next dispense is the last, and the display will remind the user to press the Plunger button and dispense the extra remaining amount of liquid. After completing the Multiple Dispensing cycle, press the Plunger button again to aspirate liquid into the tip and repeat the set MD cycle.

9.0 MIX Mode

1. Press Back button  to enter mode selection.
2. Press the Up/Down button  repeatedly until the MIX symbol flashes.
3. Press the Enter button  to confirm the selection. The COUNT symbol will then appear.
4. Use the Up/Down button  to select the desired mixing count.
5. Press the Enter button  to confirm the selection. The default pipetting volume will flash.
6. Use the Up/Down button  to select the desired mixing volume.
7. Press the Enter button  to confirm the selection. The total mixing volume and counts will be displayed.











Mixing is performed automatically by pressing the Plunger button once. After mixing is complete, pressing the Plunger button will reactivate the mixing process until the user changes the function mode.

10.0 SE (Sequential Aspirating/Dispensing) Mode

SE mode includes SA (Sequential Aspirating) mode and SD (Sequential Dispensing) mode.

10.1 SA (Sequential Aspirating) Mode

The Labnet Excel™ electronic pipettor performs repetitive aspirations of a selected volume. An air gap is created automatically between each aspiration. When the sequential aspiration is completed, the next operation will dispense all of the aspiration volume together.











1. Press the Back button  to enter function mode selection.
2. Press the Up/Down button  repeatedly until the SE symbol flashes.
3. Press the Enter button  to confirm the selection.
4. Use the Up/Down button  until the SA symbol flashes.
5. Press the Enter button  to confirm the selection.
6. Under the COUNT symbol, 01 will appear. Press the Up/Down button  to set the volume of the first aspiration.
7. Press the Enter button  to confirm the selection.
8. Repeat Steps 6 and 7 to set the sequential aspiration volumes. The total aspirating volume (including air gap volume) cannot exceed the maximum volume range.
9. Press the Enter button  to confirm the selection.
10. The count 01 and aspirating volume will appear on the display. The pipetting direction and speed  will flash to indicate that the pipettor is ready for liquid pick-up. Press the Plunger button to aspirate the samples. “A” will appear to remind the user to create an air gap (by pressing the Plunger button with the tip out of the sample) between sample aspirations.
11. When the aspirations are completed, the pipettor will make two beeping sounds and  will flash to indicate the pipettor is ready for dispensing.
12. After the sequential aspirating cycle is complete and the liquid has been dispensed, press the Plunger button to reactivate the whole cycle again until the user changes the function mode.

NOTES:

- If the blow-out setting is selected, the Labnet Excel electronic pipettor will automatically blow-out the liquid during a sequential aspiration mode.
- The Sequential Aspirating (SA) function will not perform Reverse Pipetting in System (SYS) mode (even if it is selected).

10.2. SD (Sequential Dispensing) Mode

The Labnet Excel electronic pipettor performs repetitive dispensing of various selected volumes. As with Multiple Dispensing mode, for best accuracy in SD Mode, it is recommended to select Reverse Pipetting in System Mode.

1. Press the Back button  to enter function mode selection.
2. Press the Up/Down button  repeatedly until the SE symbol flashes.
3. Press the Enter button  to confirm the selection.
4. Press the Up/Down button  repeatedly until the SD symbol flashes.
5. Press the Enter button  to confirm the selection.
6. Under the COUNT symbol, 01 will appear. Press the Up/Down button  to set the volume of the first dispense.
7. Press the Enter button  to confirm the selection.
8. Repeat Steps 6 and 7 to set the sequential dispensing volumes. **NOTE:** The total dispensing volume cannot exceed the maximum volume range.
9. Press the Enter button  to confirm the selection.
10. The count 01 and the total aspirating volume will appear on the display. The pipetting direction and speed  will flash to indicate the pipettor is ready for liquid pick-up. Press the Plunger button to aspirate the sample. When the aspiration is complete, the dispensing count and volume will appear and  will flash to indicate that the pipettor is ready for dispensing.
11. The pipettor will make two beeping sounds to remind the user of the last measured volume to dispense. At the end of the sequential dispensing cycle, if Reverse Pipettor mode is selected, “rE” will be displayed to remind the user to press the Plunger button to dispense the remaining extra amount of sample. After completing the dispensing, pressing the Plunger button again will reactivate the whole cycle until the user changes the function mode.

NOTE: If the blow-out setting is selected, the Labnet Excel™ electronic pipettor will automatically blow-out the liquid at the end of a sequential dispensing mode.

11.0 Sterilization

Only the lower piston assembly of the Labnet Excel electronic pipettor can be steam-autoclaved (121°C, 1 bar, 20 minutes).

NOTE: It is important not to exceed the temperature of 121°C or 20 minutes time during the autoclaving cycle. Autoclaving at a higher temperature or for a longer period of time may damage the manifold and will void the warranty. The autoclaved parts must be allowed to dry completely at room temperature for at least 2 hours before reassembly. Follow Figure 10 to disassemble the Labnet Excel electronic pipettor.



WARNING: Do not use excessive force to pull down the lower part before releasing the cylinder lock (Figure 9). This action may break the connection mechanism of the lower part, permanently damaging the instrument and will void the warranty.

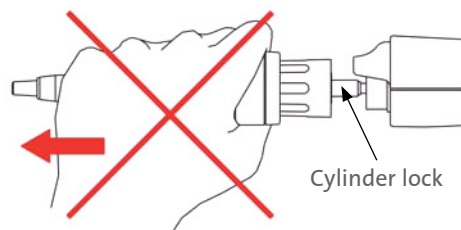

Figure 9. Incorrect removal of the lower piston assembly.



11.1 Removal of the Lower Piston Assembly

Always remember to press the Reset button before disassembling the lower part of the Labnet Excel electronic pipettor.

1. Press the Reset button. Wait until you hear two beeps.
2. Loosen the lower part of the Labnet Excel electronic pipettor by unscrewing the connecting nut in a counterclockwise direction (Figure 10A).
3. Slowly pull the lower piston assembly downward until the metal cylinder lock appears (Figure 10B).
4. Lay the Labnet Excel electronic pipettor down on a flat surface. Push the metal cylinder lock downward until you hear a click sound (Figure 10C).
5. The lower piston assembly will automatically come off easily (Figure 10D).

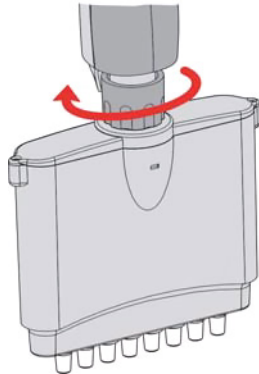

A. Loosen the connecting nut by unscrewing counter-clockwise.

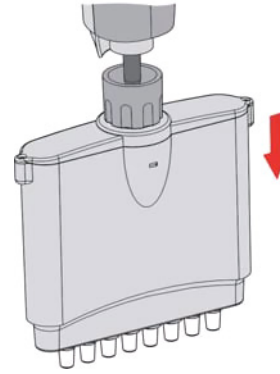

B. Slowly pull the lower piston assembly downward until the cylinder lock appears.

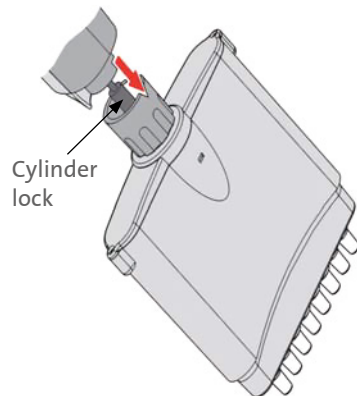

C. Push the metal cylinder lock downward until you hear a click sound.

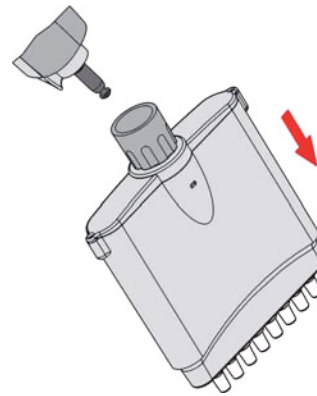

D. The lower piston assembly will automatically come off easily.

Figure 10. Removal of the lower system assembly.



11.2 Reattach the Lower Piston Assembly

NOTE: Always remember to press the Reset button after you reattach the lower piston assembly of the Labnet Excel™ electronic pipettor.

Follow these steps to reassemble the Labnet Excel electronic pipettor:

- ▶ Press the Plunger button or any button on the keypad to make the step motor shaft retract about 1 cm back into the handle. The step motor will automatically retract inside if the user does not touch any button for 10 minutes.
- ▶ Connect the lower part with the connecting nut. Tighten up the connecting nut.
- ▶ Press the Reset button. The step motor shaft will connect with the piston of the lower part automatically. After the connection is completed, the Labnet Excel electronic pipettor will beep twice.

12.0 Tip Ejector Height Adjustment

Use a flat-head screwdriver or other tool to turn the tip ejector height adjustment screw as shown in Figure 11. By turning the screw in a counterclockwise direction, the tip ejector can be adjusted down. This height adjustment feature enables efficient ejecting of different manufacturers' tips.

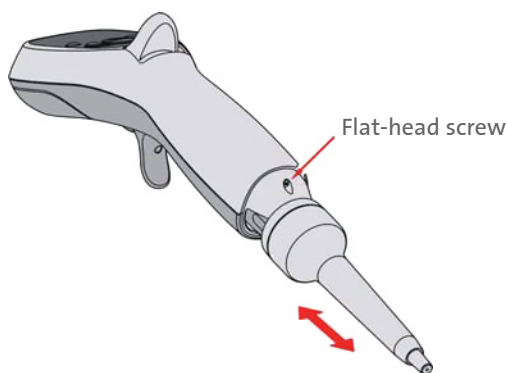

Figure 11. Tip ejector height adjustment.

13.0 Maintenance

The outside of the Labnet Excel™ electronic pipettor may be wiped clean with 60% isopropanol, 70% ethanol, or mild detergent, and then wiped dry with a lint-free cloth. If the pipettor is severely contaminated or if very corrosive chemicals are dispensed, the lower part of the Labnet electronic pipettor should be disassembled. The individual parts should be rinsed in distilled water and then air dried.

It is recommended to clean the Labnet Excel electronic pipettor at regular intervals depending on how much the pipettor is used, as well as lubricating it once per year. If the pipettor is autoclaved often, you may need to lubricate the pipettor more frequently. Lubrication of the piston should be performed only by authorized Corning representative, and only the proper Labnet Excel electronic pipettor lubricant available from Labnet should be used. For more information on the proper service of your Labnet Excel electronic pipettor, contact your Corning representative.

It is recommended to check the performance of your Labnet Excel electronic pipettor regularly (e.g., every 3 to 6 months) and always after maintenance or service. More frequent testing of the Labnet Excel electronic pipettor may be desired depending upon requirements of the application, frequency of use, number of operators using the pipettor, nature of the liquid dispensed and the acceptable maximum permissible errors established by the user (ISO 8655-1). For more information on Labnet Excel electronic pipettor calibration procedures, contact Corning Customer Service.

NOTE: Using improper lubricants may deter or block the movement of the Labnet Excel electronic pipettor's piston.

14.0 Troubleshooting

To ensure the product's quality and performance, the Labnet Excel electronic pipettor is designed with a self-diagnosis program. This program will constantly monitor the accuracy of pipetting volume, battery status, and auto-calibration function. Error (Err) messages will appear on the display if the Labnet Excel electronic pipettor fails to perform the attempted action properly. Refer to the following table to clear the error (Err) messages or faults.

If the following solutions do not resolve the problem, please contact your Corning representative to arrange for authorized service.

Message	Cause	Solution
Err 01	Battery not charged	Charge the battery.
	Faulty power adapter	Replace the power adapter.
Err 02	Auto-calibration is not working	Press the Reset button.
Err 03	Inaccurate pipetting volume	Press the Reset button.
Err 04	Step motor failure	Press the Reset button.
	Photo-couple failure	
Droplets left inside the tip	Unsuitable tip	Use quality, low retention tips.

Message	Cause	Solution
Leakage or volume too small	Non-uniform wetting of the plastic tip	Rinse the tip once prior to pipetting.
	Tip is incorrectly attached	Attach firmly.
	Unsuitable tip	Use high quality tips.
Failure to aspirate	Low battery	Charge the battery.
	The lower manifold is not correctly attached	Detach and reassemble.
	Foreign material is blocking the hole at the bottom of the cone	Use MIX mode and distilled water to wash. Air dry.
	Piston movement is blocked	Lubricate the piston.
Power on failure	Bad battery contact	Reinsert the battery.
	Rusted battery contact	Replace with a new battery.

15.0 Limited Warranty

Corning Incorporated (Corning) warrants that this product will be free from defects in material and workmanship for a period of one (1) year from date of purchase. CORNING DISCLAIMS ALL OTHER WARRANTIES WHETHER EXPRESSED OR IMPLIED, INCLUDING ANY IMPLIED WARRANTIES OF MERCHANTABILITY OR OF FITNESS FOR A PARTICULAR PURPOSE. Corning's sole obligation shall be to repair or replace, at its option, any product or part thereof that proves defective in material or workmanship within the warranty period, provided the purchaser notifies Corning of any such defect. Corning is not liable for any incidental or consequential damages, commercial loss or any other damages from the use of this product.

This warranty is valid only if the product is used for its intended purpose and within the guidelines specified in the supplied instruction manual. This warranty does not cover damage caused by accident, neglect, misuse, improper service, natural forces or other causes not arising from defects in original material or workmanship. This warranty does not cover motor brushes, fuses, batteries or damage to paint or finish. Claims for transit damage should be filed with the transportation carrier.

In the event this product fails within the specified period of time because of a defect in material or workmanship, contact Corning Customer Service at: USA/Canada 1.800.492.1110, outside the U.S. +1.978.442.2200, visit www.corning.com/lifesciences, or contact your local support office.

Corning's Customer Service team will help arrange local service where available or coordinate a return authorization number and shipping instructions. Products received without proper authorization will be returned. All items returned for service should be sent postage prepaid in the original packaging or other suitable carton, padded to avoid damage. Corning will not be responsible for damage incurred by improper packaging. Corning may elect for onsite service for larger equipment.

Some states do not allow limitation on the length of implied warranties or the exclusion or limitation of incidental or consequential damages. This warranty gives you specific legal rights. You may have other rights which vary from state to state.

No individual may accept for, or on behalf of Corning, any other obligation of liability, or extend the period of this warranty.

For your reference, make a note of the serial and model number, date of purchase, and supplier here.

Serial No. _____ Date Purchased _____

Model No. _____ Supplier _____

16.0 Equipment Disposal



According to Directive 2012/19/EU of the European Parliament and of the Council of 4 July 2012 on waste electrical and electronic equipment (WEEE), this product is marked with the crossed-out wheeled bin and must not be disposed of with domestic waste.

Consequently, the buyer shall follow the instructions for reuse and recycling of waste electronic and electrical equipment (WEEE) provided with the products and available at www.corning.com/weee.

To request certificates, please contact us at www.labnetlink.com.

Warranty/Disclaimer: Unless otherwise specified, all products are for research use or general laboratory use only.* Not intended for use in diagnostic or therapeutic procedures. Not for use in humans. These products are not intended to mitigate the presence of microorganisms on surfaces or in the environment, where such organisms can be deleterious to humans or the environment. Corning Life Sciences makes no claims regarding the performance of these products for clinical or diagnostic applications. *For a listing of US medical devices, regulatory classifications or specific information on claims, visit www.corning.com/resources.

CORNING

Corning Incorporated
Life Sciences

www.corning.com/lifesciences

NORTH AMERICA

t 800.492.1110
t 978.442.2200

ASIA/PACIFIC

Australia/New Zealand
t 61 427286832
Chinese Mainland
t 86 21 3338 4338

India

t 91 124 4604000

Japan

t 81 3-3586 1996

Korea

t 82 2-796-9500

Singapore

t 65 6572-9740

Taiwan

t 886 2-2716-0338

EUROPE

CSEurope@corning.com

LATIN AMERICA

grupolA@corning.com

Brazil

t 55 (11) 3089-7400

Mexico

t (52-81) 8158-8400